



Compressor
Voltage Code : TZ

TAJ4517Z-TZ

High Temp. Commercial (HP)

400V 3~ 50Hz / 440V 3~ 60 Hz

R452A / R404A / R448A / R449A / R407C / R22

AJ4517Z-TZ1C

Conditions	Frequency	Nominal Cooling Capacity		Sound Power ISO3745 / ISO 3743-1
		Watts	BTU/h	
EN12900_HP / R452A	50 Hz / 60 Hz	3409 / 3947	11625 / 13459	62 dBA
EN12900_HP / R404A	50 Hz / 60 Hz	3372 / 3906	11498 / 13319	62 dBA
EN12900_HP / R448A	50 Hz / 60 Hz	3497 / 4046	11926 / 13798	62 dBA
EN12900_HP / R449A	50 Hz / 60 Hz	3491 / 4040	11905 / 13775	62 dBA
EN12900_HP / R407C	50 Hz / 60 Hz	3354 / 3880	11437 / 13230	
EN12900_HP / R22	50 Hz / 60 Hz	3385 / 3922	11544 / 13374	

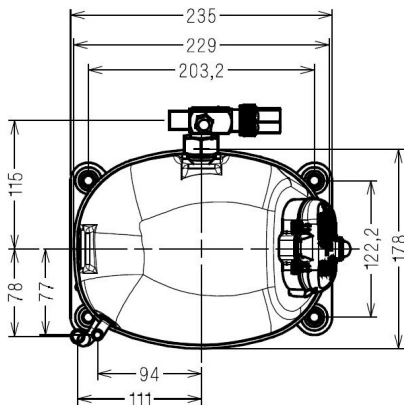
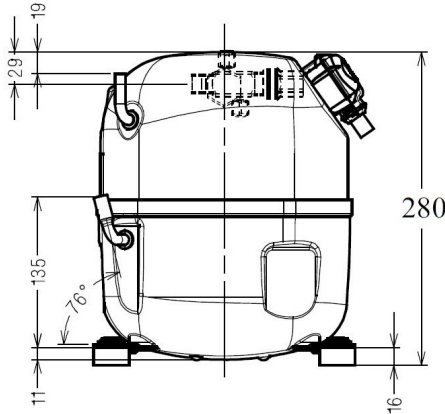

Displacement (cc)	25,95
Net Weight (Kg)	20.0
Oil Quantity (cc)	475.0
Oil Type	Polyolester
Expansion Device	Capillary_Tube/Expansion_Valve
Cooling	Fan
Main Winding (Ohm)	11.0
Current	
RLA (A)	3 3
MCC (A)	4.4 4.8
LRA (A)	18 18
Electrical Equipment	TRI
Overload	Interne
Refrigerating connection for	
Suction Tube	15.9 (5/8")
Discharge Tube	9.5 (3/8")
Process Tube	6.35 (1/4")

* EN12900_HP : T°Cond. 50.0°C / T°Evap. 5.0°C / T°Return gas temp.. 20.0°C
T°Subcooling. 0.0K

Certificates :

Note : Tecumseh reserves the right to change information contained in this document without notification.



Tecumseh

TAJ4517Z-TZ	Tension TZ : 400V 3~ 50Hz / 440V 3~ 60 Hz
--------------------	--

Les performances sont données dans les **conditions EN12900_HP** :
 Condition Mid
 The performance data are in **EN12900_HP conditions** :
 Mid Condition

Gaz aspirés : 20.0 °C
 Sous refroidissement : 0.0 K
 Return gas : 20.0 °C
 Subcooling : 0.0 K

© 2024 Tecumseh Products Company
All rights reserved

50 Hz R452A

N°2287

4 T condensation	5 T évaporation	(°C)	-25	-20	-15	-10	-5	0	5	10	15
30	1 P frigorifique	(Watt)	1285	1715	2209	2781	3441	4200	5070	6062	7187
	2 P absorbée	(W)	777	871	955	1033	1106	1176	1247	1320	1397
	3 I absorbée	(A)	1.92	2.03	2.13	2.22	2.32	2.40	2.48	2.56	2.64
40	1 P frigorifique	(Watt)		1344	1785	2285	2855	3506	4250	5097	6060
	2 P absorbée	(W)		907	1021	1125	1222	1313	1402	1490	1580
	3 I absorbée	(A)		2.06	2.21	2.35	2.48	2.62	2.74	2.87	2.99
50	1 P frigorifique	(Watt)			1353	1777	2254	2794	3409	4109	4907
	2 P absorbée	(W)			1059	1198	1326	1447	1561	1672	1782
	3 I absorbée	(A)			2.25	2.43	2.61	2.79	2.97	3.14	3.30
60	1 P frigorifique	(Watt)				1272	1653	2079	2562	3113	3744
	2 P absorbée	(W)				1238	1406	1563	1711	1853	1991
	3 I absorbée	(A)				2.48	2.71	2.93	3.15	3.37	3.58

60 Hz R452A

N°2287

4 T condensation	5 T évaporation	(°C)	-25	-20	-15	-10	-5	0	5	10	15
30	1 P frigorifique	(Watt)	1537	2038	2599	3234	3960	4790	5739	6823	8055
	2 P absorbée	(W)	914	1045	1158	1260	1358	1459	1570	1699	1852
	3 I absorbée	(A)	1.70	1.82	1.95	2.08	2.21	2.34	2.48	2.62	2.77
40	1 P frigorifique	(Watt)		1606	2123	2693	3330	4050	4868	5797	6853
	2 P absorbée	(W)		1060	1219	1358	1484	1605	1728	1859	2006
	3 I absorbée	(A)		1.85	2.01	2.18	2.34	2.52	2.70	2.88	3.06
50	1 P frigorifique	(Watt)			1613	2113	2659	3265	3947	4718	5595
	2 P absorbée	(W)			1225	1418	1589	1747	1897	2047	2204
	3 I absorbée	(A)			2.04	2.25	2.46	2.67	2.88	3.11	3.33
60	1 P frigorifique	(Watt)				1513	1963	2452	2995	3606	4300
	2 P absorbée	(W)				1418	1651	1860	2054	2239	2422
	3 I absorbée	(A)				2.29	2.54	2.79	3.04	3.30	3.57

1 = cooling capacity 2 = power input 3 = current 4 = condensing temperature 5 = evaporating temperature

Nota : Tecumseh se réserve le droit de modifier les informations contenues dans ce document sans préavis.

Note : Tecumseh reserves the right to change information contained in this document without notification.



Tecumseh

TAJ4517Z-TZ	Tension TZ : 400V 3~ 50Hz / 440V 3~ 60 Hz
--------------------	--

Les performances sont données dans les **conditions EN12900_HP** :
 Condition Mid
 The performance data are in **EN12900_HP conditions** :
 Mid Condition

Gaz aspirés : 20.0 °C
 Sous refroidissement : 0.0 K
 Return gas : 20.0 °C
 Subcooling : 0.0 K

© 2024 Tecumseh Products Company
All rights reserved

50 Hz R404A

N°224LU-TZ

4 T condensation	5 T évaporation	(°C)	-25	-20	-15	-10	-5	0	5	10	15
30	1 P frigorifique	(Watt)	1341	1764	2249	2807	3447	4180	5016	5967	7041
	2 P absorbée	(W)	796	888	970	1044	1113	1179	1244	1310	1380
	3 I absorbée	(A)	2.01	2.11	2.20	2.28	2.36	2.43	2.50	2.56	2.62
40	1 P frigorifique	(Watt)	1001	1393	1828	2317	2870	3498	4210	5018	5931
	2 P absorbée	(W)	809	932	1043	1143	1235	1320	1402	1482	1562
	3 I absorbée	(A)	2.01	2.15	2.28	2.41	2.54	2.65	2.77	2.87	2.98
50	1 P frigorifique	(Watt)		1013	1393	1809	2271	2788	3372	4032	4780
	2 P absorbée	(W)		945	1092	1225	1348	1461	1567	1669	1768
	3 I absorbée	(A)		2.16	2.34	2.51	2.68	2.84	3.00	3.15	3.30
60	1 P frigorifique	(Watt)			960	1298	1664	2066	2517	3026	3603
	2 P absorbée	(W)			1105	1280	1441	1590	1729	1860	1986
	3 I absorbée	(A)			2.37	2.58	2.80	3.00	3.20	3.40	3.59

60 Hz R404A

N°224LU-TZ

4 T condensation	5 T évaporation	(°C)	-25	-20	-15	-10	-5	0	5	10	15
30	1 P frigorifique	(Watt)	1604	2097	2646	3265	3967	4767	5677	6713	7887
	2 P absorbée	(W)	937	1066	1176	1274	1367	1462	1565	1685	1827
	3 I absorbée	(A)	1.78	1.89	2.00	2.12	2.24	2.36	2.49	2.61	2.74
40	1 P frigorifique	(Watt)	1188	1665	2175	2731	3349	4042	4823	5707	6707
	2 P absorbée	(W)	907	1090	1246	1380	1501	1614	1728	1849	1983
	3 I absorbée	(A)	1.77	1.92	2.07	2.23	2.39	2.55	2.71	2.88	3.04
50	1 P frigorifique	(Watt)		1198	1662	2152	2680	3260	3906	4632	5452
	2 P absorbée	(W)		1047	1264	1451	1616	1765	1905	2043	2186
	3 I absorbée	(A)		1.93	2.12	2.32	2.51	2.71	2.91	3.11	3.32
60	1 P frigorifique	(Watt)			1129	1545	1977	2439	2944	3507	4141
	2 P absorbée	(W)			1210	1467	1692	1892	2075	2248	2416
	3 I absorbée	(A)			2.15	2.38	2.61	2.85	3.09	3.33	3.57

1 = cooling capacity 2 = power input 3 = current 4 = condensing temperature 5 = evaporating temperature

Nota : Tecumseh se réserve le droit de modifier les informations contenues dans ce document sans préavis.

Note : Tecumseh reserves the right to change information contained in this document without notification.



Tecumseh

TAJ4517Z-TZ	Tension TZ : 400V 3~ 50Hz / 440V 3~ 60 Hz
--------------------	--

Les performances sont données dans les conditions EN12900_HP :	Gaz aspirés :	20.0 °C
Condition Mid	Sous refroidissement :	0.0 K
The performance data are in EN12900_HP conditions :	Return gas :	20.0 °C
Mid Condition	Subcooling :	0.0 K

50 Hz R448A (*)											
											N°2889
4 T condensation	5 T évaporation	(°C)	-25	-20	-15	-10	-5	0	5	10	15
30	1 P frigorifique	(Watt)	1190	1614	2107	2681	3347	4117	5004	6020	7175
	2 P absorbée	(W)	742	828	908	983	1054	1123	1191	1260	1331
	3 I absorbée	(A)	1.81	1.91	2.01	2.10	2.20	2.28	2.36	2.44	2.50
40	1 P frigorifique	(Watt)		1275	1717	2224	2808	3480	4254	5140	6151
	2 P absorbée	(W)		871	978	1078	1171	1260	1345	1428	1511
	3 I absorbée	(A)		1.96	2.10	2.23	2.37	2.50	2.62	2.74	2.85
50	1 P frigorifique	(Watt)			1325	1764	2265	2839	3497	4253	5118
	2 P absorbée	(W)			1022	1157	1282	1401	1513	1621	1726
	3 I absorbée	(A)			2.15	2.34	2.52	2.69	2.86	3.03	3.19
60	1 P frigorifique	(Watt)				1319	1736	2210	2753	3378	4097
	2 P absorbée	(W)				1203	1371	1528	1678	1820	1957
	3 I absorbée	(A)				2.39	2.63	2.85	3.08	3.30	3.51

60 Hz R448A (*)											
											N°2889
4 T condensation	5 T évaporation	(°C)	-25	-20	-15	-10	-5	0	5	10	15
30	1 P frigorifique	(Watt)	1422	1917	2476	3115	3849	4693	5663	6775	8041
	2 P absorbée	(W)	876	996	1102	1200	1295	1394	1501	1624	1767
	3 I absorbée	(A)	1.61	1.72	1.84	1.97	2.10	2.23	2.36	2.50	2.64
40	1 P frigorifique	(Watt)		1523	2040	2619	3273	4018	4870	5843	6953
	2 P absorbée	(W)		1020	1169	1301	1423	1540	1658	1783	1920
	3 I absorbée	(A)		1.76	1.92	2.08	2.24	2.41	2.58	2.75	2.93
50	1 P frigorifique	(Watt)			1580	2097	2669	3314	4046	4881	5834
	2 P absorbée	(W)			1186	1371	1538	1692	1839	1984	2135
	3 I absorbée	(A)			1.96	2.16	2.37	2.58	2.79	3.01	3.22
60	1 P frigorifique	(Watt)				1570	2060	2604	3215	3910	4704
	2 P absorbée	(W)				1381	1611	1820	2014	2199	2381
	3 I absorbée	(A)				2.21	2.46	2.72	2.98	3.24	3.50

1 = cooling capacity 2 = power input 3 = current 4 = condensing temperature 5 = evaporating temperature

(*) Veuillez vous référer strictement aux Recommandations d'Utilisation et Bulletins Marketing Tecumseh du fait de la température de refoulement élevée pour les applications LBP.
 (*) Due to very high discharge temperature especially on LBP conditions, please strictly refer to Tecumseh Guidelines & Marketing Bulletin when using this refrigerant.

Nota : Tecumseh se réserve le droit de modifier les informations contenues dans ce document sans préavis.
Note : Tecumseh reserves the right to change information contained in this document without notification.

© 2024 Tecumseh Products Company
All rights reserved



Tecumseh

TAJ4517Z-TZ	Tension TZ : 400V 3~ 50Hz / 440V 3~ 60 Hz
--------------------	--

Les performances sont données dans les conditions EN12900_HP :	Gaz aspirés :	20.0 °C
Condition Mid	Sous refroidissement :	0.0 K
The performance data are in EN12900_HP conditions :	Return gas :	20.0 °C
Mid Condition	Subcooling :	0.0 K

© 2024 Tecumseh Products Company
All rights reserved

50 Hz R449A (*)

N°2283

4 T condensation	5 T évaporation	(°C)	-25	-20	-15	-10	-5	0	5	10	15
30	1 P frigorifique	(Watt)	1187	1611	2104	2677	3342	4112	4999	6014	7170
	2 P absorbée	(W)	741	828	908	982	1053	1122	1190	1259	1330
	3 I absorbée	(A)	1.81	1.91	2.01	2.10	2.19	2.28	2.36	2.44	2.50
40	1 P frigorifique	(Watt)		1272	1713	2220	2803	3475	4248	5134	6144
	2 P absorbée	(W)		870	977	1077	1170	1259	1344	1428	1511
	3 I absorbée	(A)		1.96	2.10	2.23	2.37	2.50	2.62	2.74	2.85
50	1 P frigorifique	(Watt)			1321	1760	2260	2833	3491	4247	5111
	2 P absorbée	(W)			1021	1156	1282	1400	1513	1621	1726
	3 I absorbée	(A)			2.15	2.33	2.51	2.69	2.86	3.03	3.19
60	1 P frigorifique	(Watt)				1315	1731	2204	2747	3371	4089
	2 P absorbée	(W)				1202	1370	1528	1677	1820	1957
	3 I absorbée	(A)				2.39	2.62	2.85	3.08	3.30	3.51

60 Hz R449A (*)

N°2283

4 T condensation	5 T évaporation	(°C)	-25	-20	-15	-10	-5	0	5	10	15
30	1 P frigorifique	(Watt)	1419	1913	2472	3110	3844	4688	5657	6768	8035
	2 P absorbée	(W)	875	995	1101	1199	1294	1393	1500	1623	1766
	3 I absorbée	(A)	1.61	1.72	1.84	1.97	2.10	2.23	2.36	2.50	2.64
40	1 P frigorifique	(Watt)		1519	2036	2614	3267	4012	4863	5837	6947
	2 P absorbée	(W)		1019	1168	1300	1422	1539	1657	1782	1920
	3 I absorbée	(A)		1.76	1.91	2.07	2.24	2.41	2.58	2.75	2.93
50	1 P frigorifique	(Watt)			1576	2092	2664	3308	4040	4874	5826
	2 P absorbée	(W)			1184	1370	1537	1691	1838	1984	2134
	3 I absorbée	(A)			1.96	2.16	2.37	2.58	2.79	3.00	3.22
60	1 P frigorifique	(Watt)				1565	2055	2597	3208	3902	4695
	2 P absorbée	(W)				1379	1610	1819	2014	2199	2381
	3 I absorbée	(A)				2.21	2.46	2.72	2.98	3.24	3.50

1 = cooling capacity 2 = power input 3 = current 4 = condensing temperature 5 = evaporating temperature

(*) Veuillez vous référer strictement aux Recommandations d'Utilisation et Bulletins Marketing Tecumseh du fait de la température de refoulement élevée pour les applications LBP.

(*) Due to very high discharge temperature especially on LBP conditions, please strictly refer to Tecumseh Guidelines & Marketing Bulletin when using this refrigerant.

Nota : Tecumseh se réserve le droit de modifier les informations contenues dans ce document sans préavis.

Note : Tecumseh reserves the right to change information contained in this document without notification.



Tecumseh

TAJ4517Z-TZ	Tension TZ : 400V 3~ 50Hz / 440V 3~ 60 Hz
--------------------	--

Les performances sont données dans les conditions EN12900_HP :	Gaz aspirés :	20.0 °C
Condition Mid	Sous refroidissement :	0.0 K
The performance data are in EN12900_HP conditions :	Return gas :	20.0 °C
Mid Condition	Subcooling :	0.0 K

© 2024 Tecumseh Products Company
All rights reserved

50 Hz R407C

N°3677

4 T condensation	5 T évaporation	(°C)	-20	-15	-10	-5	0	5	10	15
40	1 P frigorifique	(Watt)			2601	3313	4145	5115	6242	7545
	2 P absorbée	(W)			1021	1110	1193	1273	1351	1429
	3 I absorbée	(A)			2.11	2.24	2.36	2.48	2.59	2.69
50	1 P frigorifique	(Watt)				2421	3063	3810	4677	5679
	2 P absorbée	(W)				1210	1323	1431	1534	1636
	3 I absorbée	(A)				2.37	2.54	2.71	2.86	3.02
60	1 P frigorifique	(Watt)					2124	2670	3304	4036
	2 P absorbée	(W)					1436	1579	1716	1849
	3 I absorbée	(A)					2.68	2.89	3.10	3.31

60 Hz R407C

N°3677

4 T condensation	5 T évaporation	(°C)	-20	-15	-10	-5	0	5	10	15
40	1 P frigorifique	(Watt)			3061	3860	4785	5856	7096	8530
	2 P absorbée	(W)			1233	1349	1459	1569	1687	1817
	3 I absorbée	(A)			1.97	2.12	2.28	2.44	2.60	2.77
50	1 P frigorifique	(Watt)				2853	3576	4408	5366	6471
	2 P absorbée	(W)				1451	1598	1739	1879	2024
	3 I absorbée	(A)				2.23	2.43	2.64	2.84	3.05
60	1 P frigorifique	(Watt)					2502	3118	3824	4634
	2 P absorbée	(W)					1711	1896	2074	2250
	3 I absorbée	(A)					2.55	2.80	3.05	3.31

1 = cooling capacity 2 = power input 3 = current 4 = condensing temperature 5 = evaporating temperature

Nota : Tecumseh se réserve le droit de modifier les informations contenues dans ce document sans préavis.

Note : Tecumseh reserves the right to change information contained in this document without notification.



Tecumseh

TAJ4517Z-TZ	Tension TZ : 400V 3~ 50Hz / 440V 3~ 60 Hz
--------------------	--

Les performances sont données dans les conditions EN12900_HP :	Gaz aspirés :	20.0 °C
Condition Mid	Sous refroidissement :	0.0 K
The performance data are in EN12900_HP conditions :	Return gas :	20.0 °C
Mid Condition	Subcooling :	0.0 K

50 Hz R22										
N°3683										
4 T condensation	5 T évaporation	(°C)	-20	-15	-10	-5	0	5	10	15
40	1 P frigorifique	(Watt)	1254	1650	2108	2636	3244	3943	4741	5650
	2 P absorbée	(W)	857	954	1041	1121	1196	1268	1340	1415
	3 I absorbée	(A)	1.98	2.09	2.20	2.31	2.41	2.51	2.60	2.70
50	1 P frigorifique	(Watt)	986	1345	1756	2226	2766	3385	4094	4902
	2 P absorbée	(W)	879	1010	1129	1238	1340	1437	1531	1625
	3 I absorbée	(A)	2.02	2.17	2.32	2.47	2.61	2.75	2.90	3.03
60	1 P frigorifique	(Watt)		1046	1406	1817	2286	2825	3442	4147
	2 P absorbée	(W)		1039	1197	1344	1480	1609	1732	1854
	3 I absorbée	(A)		2.23	2.42	2.61	2.80	2.98	3.17	3.35

60 Hz R22										
N°3683										
4 T condensation	5 T évaporation	(°C)	-20	-15	-10	-5	0	5	10	15
40	1 P frigorifique	(Watt)	1498	1963	2485	3076	3749	4517	5393	6388
	2 P absorbée	(W)	1001	1139	1257	1363	1463	1563	1672	1795
	3 I absorbée	(A)	1.77	1.90	2.03	2.17	2.31	2.45	2.60	2.76
50	1 P frigorifique	(Watt)	1165	1605	2088	2627	3234	3922	4703	5591
	2 P absorbée	(W)	974	1169	1337	1485	1619	1747	1875	2009
	3 I absorbée	(A)	1.80	1.97	2.14	2.31	2.49	2.67	2.86	3.05
60	1 P frigorifique	(Watt)		1232	1674	2159	2698	3304	3990	4769
	2 P absorbée	(W)		1139	1372	1577	1761	1931	2093	2255
	3 I absorbée	(A)		2.02	2.23	2.44	2.65	2.87	3.10	3.33

1 = cooling capacity 2 = power input 3 = current 4 = condensing temperature 5 = evaporating temperature

Nota : Tecumseh se réserve le droit de modifier les informations contenues dans ce document sans préavis.

Note : Tecumseh reserves the right to change information contained in this document without notification.

© 2024 Tecumseh Products Company
All rights reserved