

WATER MOTOR GONG WMG

page 1 of 4

Profit water motor gong type WMG is a hydraulically automated sound device actuated by water flow. The gong is intended to use on alarm check valves in fire protection sprinkler systems. Brand: WEFLO.

Characteristics

- In- and outdoor use.
- Self contained , line pressure operated.
- Quick response 90 dB sound level.
- Wheaterproof anti-corrosion protected.
- Connections:
 - Inlet $\frac{3}{4}$ " npt
 - Outlet drain : 1" npt

Working pressure

- 0,5 to 20,7 barg /300 PSI

Working temperature

- +1 to + 87 °CPSI

Weight

- 2,270kg

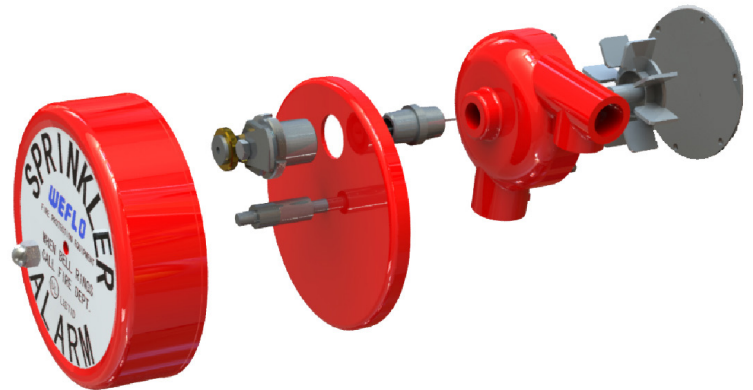

Operation

When an alarm valve is activated, water flows through the valve's trim, discharges to a strainer and into the water motor inlet. From the inlet, the water flows through a nozzle which directs the stream to the impeller. The stream turns the impeller and drive shaft, causing the striker arm to rotate, thus producing a continuous alarm. The water is discharged through a 1" (25 mm) drain outlet at the bottom of the impeller housing. The discharged water must be piped through the wall to atmosphere or to a suitable open drain.

WATER MOTOR GONG WMG

Material specifications

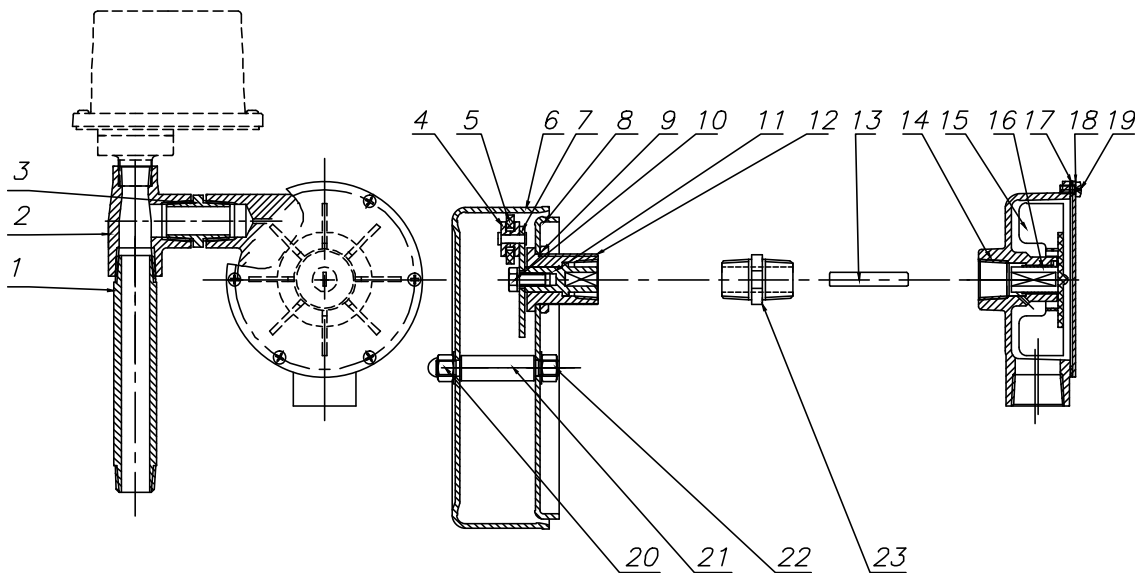

Part N°	Part Name	Material
1	Inlet Pipe	Carbon Steel
2	Tee-junction	Malleable Iron
3	Joint	Stainless Steel, SS304
4	Striker Fixed Block	Aluminum Alloy
5	Striker Ring	Synthetic Nylon
6	Gong	Aluminum Alloy
7	Striker Alarm	Stainless Steel
8	Gong Frame	Aluminum Plate
9	Round Nut	Stainless Steel, SS304
10	Bolt	Stainless Steel, A2-70
11	Coupling	POM
12	Striker Shaft Bearing	Aluminum Alloy
13	Drive Shaft	Stainless Steel, SS304
14	Water Motor	Cast Aluminum
15	Impeller	POM
16	Sleeve	POM
17	Gasket	Rubber, NBR
18	Cover	Aluminum Alloy
19	Screw	Stainless Steel, A2-70
20	Nut/Spring Washer	Stainless Steel, SS304
21	Back Shaft	Aluminum Alloy
22	Lock Nut	Stainless Steel, SS304
23	Drive Shaft Sleeve	Stainless Steel, SS304

Marking



Storage and handling

- Upon receipt, carefully check the water motor gong on any damage during shipment.



Installation

- Inspection before installation. Checklist:
 1. Locate and cut a proper hole through the building wall to accommodate a 3/4" diameter support pipe.
 2. Cut and thread both ends of 3/4" diameter steel support pipe, length of the support pipe should be equal to the wall thickness plus 16mm for tapping the 3/4" NPT threads.
 3. Measure and cut the drive shaft to take a length as the support pipe plus 2-1/2" long, and remove the burrs.
 4. Insert the drive shaft into the Coupling of gong, and rotate to strike the gong.
 5. Insert the support pipe into the building wall and let the gong closed to the wall.
 6. Spin the water motor by means of 3/4"-14 NPT thread into the support pipe, locate the 1"NPT female thread drain downward.
 7. Retainer insert into water motor body.
 8. Impeller insert into retainer and connect with the drive shaft, with manual rotate the impeller to strike and get the gong voice.
 9. Assemble the gasket and cover, and set the screw.
 10. Water motor body to be connected with retard chamber, pressure switch and pressure gauge.
 11. A 1" drain pipe line is connection to the 1"NPT female thread drain.
 12. Test and check the whole assembly and make sure the system in normal conditions.

**Maintenance**

The owner is responsible for the inspection, testing, and maintenance of their fire protection system and devices in compliance with this document, as well as with the applicable standards of the National Fire Protection Association (e.g., NFPA 25), in addition to the standards of any authority having jurisdiction. The installing contractor or product manufacturer should be contacted relative to any questions. It is recommended that automatic sprinkler systems be inspected, tested, and maintained by a qualified Inspection Service in accordance with local requirements and/or national codes.